

The following article was published in ASHRAE Journal, January 1997. © Copyright 1997 American Society of Heating, Refrigerating and Air-Conditioning Engineers, Inc. It is presented for educational purposes only. This article may not be copied and/or distributed electronically or in paper form without permission of ASHRAE.

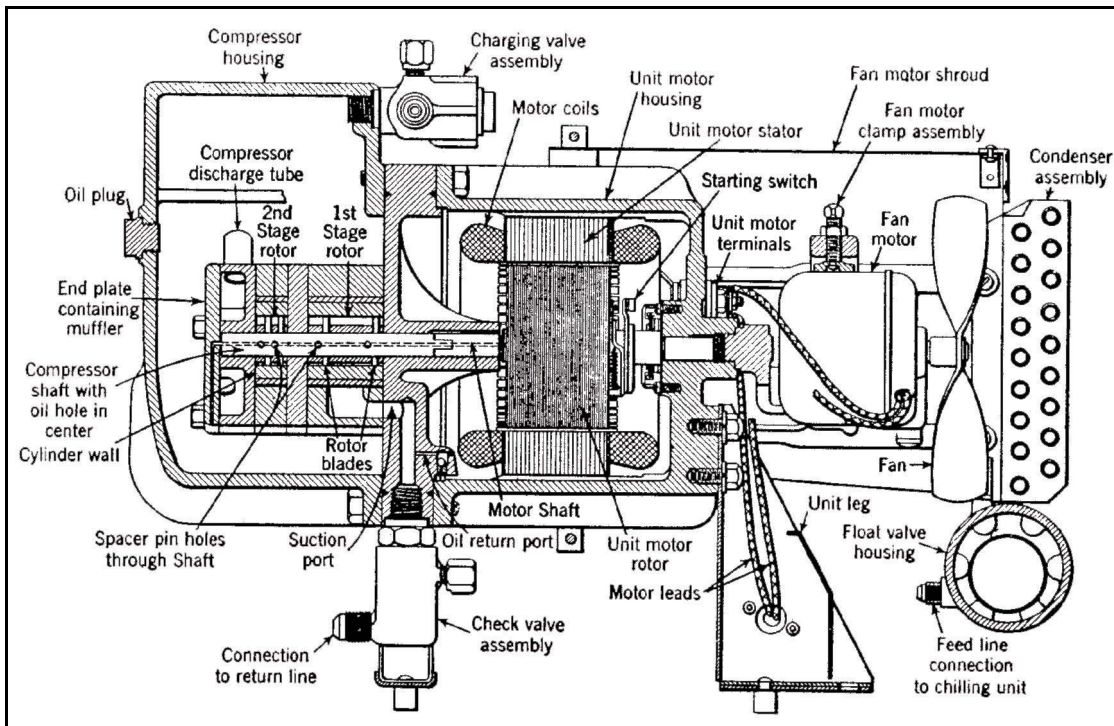

Figure 1: The Holmes refrigerating unit, manufactured in 1928 and 1929, featured a two-stage rotary compressor. Like the Allison, the Holmes used a hermetic blade-type rotary compressor with ethyl chloride as the refrigerant. (From: Master Service Manual, #3, "Household refrigeration installation and service")

History of Sealed Refrigeration Systems

By Bernard A. Nagengast
Member ASHRAE

This article continues the history of sealed refrigeration systems which began in the January 1996 issue of *ASHRAE Journal*. In that article, three externally driven sealed systems, and three internal drive designs were discussed.

The first sealed systems were not mass-produced until after 1925. Most of the engineering efforts concentrated on developing internally driven compressors without shaft seals and gaskets. This meant that the compressor and motor had to be contained in a refrigerant tight casing.

The first article introduced the first of these designs to be produced in quantity, the General Electric OC-2, but failed to mention the inventor. The OC-2 was developed by Clark Orr, a "master mechanic" and a self-made engineer. Orr retired from General Electric in 1939, having worked at the Ft. Wayne, Ind. division for 48 years.

The first part of this article described three hermetic compressors identified

as: (1) Stokes, (2) Utility and (3) General Electric OC-2. This installment covers the (4) Allison, (5) Holmes, (6) General Electric DR, (7) Westinghouse SD, and Williams Ice-O-Matic.

The impetus for sealed systems

During the 1920s there was only one reason to seek successful sealed refrigeration systems. That reason was the electric household refrigerator. Although some mechanical refrigerators were produced as early as the 1890s, the many significant technical impediments to their wide adoption were not overcome until the mid-1920s.¹

There were many various designs of household electric refrigerators introduced after WW I, and most used open drive compressors. Hermetic compressors were seldom seen before the mid-1930s, but all electric refrigerators produced in the U.S. for household use had hermetic compressors by the 1940s.

(4) **Allison:** The Domestic Electric Refrigerator Corporation was founded in 1926 in New York City. The company produced household refrigerators for about two years, but was out of business by 1930.

The Allison refrigerator used a hermetic blade type rotary compressor with ethyl chloride refrigerant, and thus operated at low pressures. The motor-compressor was horizontal, and sealed in a pressed steel and cast iron casing which was bolted together. The compressor was two-stage, using two 4-blade rotors. "Points of contact between the rotors

**See Nagengast
Continued on page S46**

About the Author

Bernard Nagengast is a consulting engineer in Sidney, Ohio who has been researching the history of HVAC&R for 25 years. He is a consultant to, and past chairman of the ASHRAE Historical Committee. Much of his work was published in 1995 in ASHRAE's Centennial history book -- *Heat & Cold: Mastering the Great Indoors, A Selective History of Heating, Ventilation, Refrigeration and Air Conditioning*. The book is available from ASHRAE publications.

Advertisement in the print
edition formerly in this space.

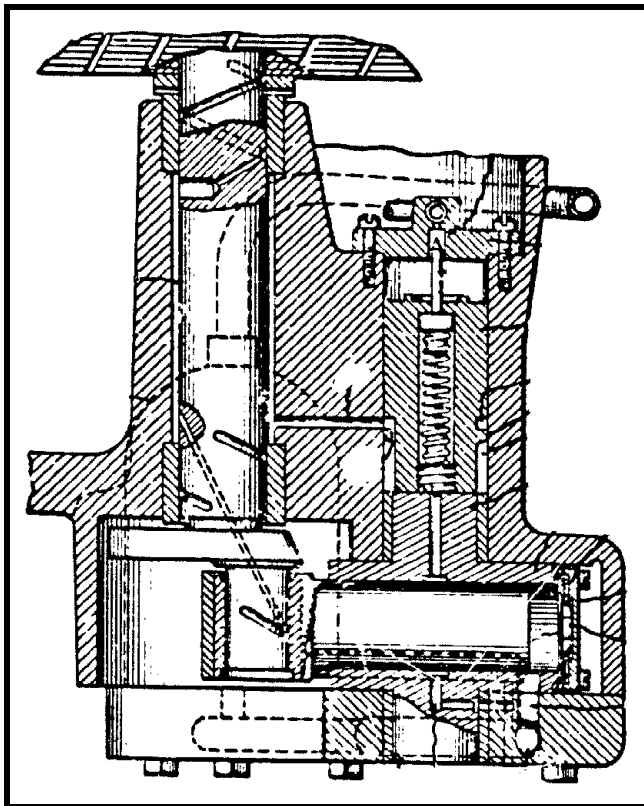

Figure 2: Crosssection of General Electric DR compressor body from Christian Steenstrup's patent.

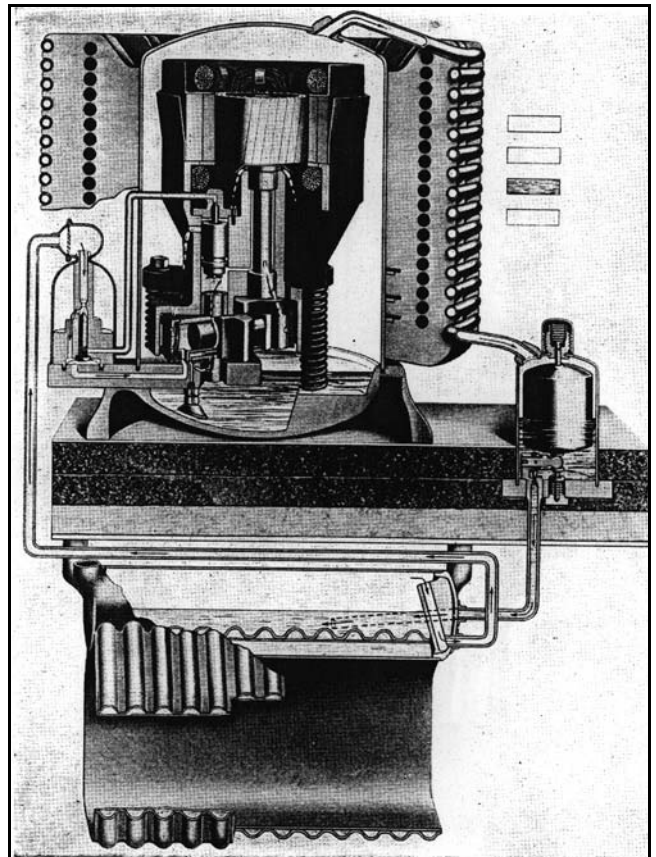

Figure 3: GE DR refrigeration system crosssection. (From: Hull, H. 1933. Household Electric Refrigeration)

Nagengast

Continued from page S44

and the cylinder are made by means of 'wiper blades' which fit into the rotor blades in such a manner as to ensure a rocker action and provide adequate contact of the blade to the cylinder wall.

The ability of these blades to pick up gas from the in-port of the compressor, compress the gas, and hold their contact to the cylinder walls depends on the eccentric assembly of the rotors in relation to the cylinder wall. Some assistance is given these blades by a special design of spacer pins which force the blades to actuate upon each revolution of the rotor, although centrifugal force alone presumably is strong enough to maintain sufficient contact.²

The compressor featured pressure lubricated bearings and the casing was exposed to the high-side pressure. The motor was a 1/8 horsepower 1725 RPM split-phase type using a centrifugal starting switch mounted on the motor shaft.

The author has not located any additional information on the Allison compressor.

(5) **Holmes:** The Holmes refrigerator was manufactured by Holmes Products Inc. in 1928 and 1929 in New York City. The compressor used was almost identical to the Allison described above, and the author suspects that Holmes was the successor to Allison. The two companies have addresses next door to each other!

The Holmes compressor was manufactured under patents owned by Westinghouse, and, like the Allison, used ethyl chloride refrigerant.³ The operation of the Holmes rotary two-stage compressor is as described above for the Allison compressor (Figure 1).

(6) **General Electric DR:** The first part of this series described a sealed system manufactured by General Electric in 1925 and 1926, designated as model OC-2. This system incorporated a hermetic compressor.

Only 2000 model OC refrigerating units were produced, although 10,000 were authorized, because it became evident that a lower cost and more reliable system was needed. In 1925, General

Electric's refrigeration engineers were requested to submit designs for a new household refrigerator. Of those suggested, a committee selected one incorporating an oscillating cylinder, bolted shell compressor, designed by Christian Steenstrup. As supervisor of mechanical research for GE, Steenstrup was able to conceive, design and build a compressor in three weeks!

Design, promote, solve problems!

Steenstrup's compressor (US patent 1,736,635 of Nov. 19, 1929) was of a vertical design with the motor on top. It used a single cylinder which oscillated about two vertical trunnions on a steel bearing plate to allow intake porting for the refrigerant vapor as the piston moved back and fourth from the crank on the lower end of the shaft (Figure 2).

A small piston supplied pressurized lubricating oil to the bearings and this oil also operated an unloader which served to

See Nagengast
Continued on page S49

Advertisement in the print
edition formerly in this space.

Advertisement in the print
edition formerly in this space.



**FIRE AND FLOOD
AND RAGING BLIZZARD**

**powerless to check the dependable operation
of THE MONITOR TOP***

Never—through all its years of faithful service in the peace and quiet of a home—will the General Electric Refrigerator be required to withstand such tests as these. But what years of service may be expected from the refrigerator that can survive the most terrific ravages of time and wear! In the Monitor Top, the entire mechanism is fortified against air, dirt and moisture with impregnable walls of steel. Buried in sand, frozen in ice, drowned in water, roasted in flames, the General Electric Refrigerator still ran on!

Here is a refrigerator that will wear like steel—because it is steel. A refrigerator—modern as electricity—because it is electric. A refrigerator built with the ingenuity, skill and sterling craftsmanship associated with the name "General Electric"—because it is General Electric!

GENERAL ELECTRIC
ALL-STEEL REFRIGERATOR
ELECTRIC WATER COOLERS • COMMERCIAL REFRIGERATORS • ELECTRIC MILK COOLERS

Figure 4: Ads touted the indestructibility of the sealed refrigeration unit. (From: Fortune October, 1930)

Nagengast

Continued from page S46

equalize the refrigerant pressure on both sides of the piston during the off-cycle.⁴ The patent shows what is now considered a modern idea - a disc-type discharge valve of an area almost as large as the cylinder. The compressed refrigerant (sulfur dioxide) passed through a muffler into the shell area, and then out through a copper tube hydrogen brazed into the top of the shell, and into the air-cooled condenser.

The motor was a 1/8 horsepower 1740 RPM split-phase type with an external current type relay for disconnecting the starting winding. The stator was wound with triple wrapped cotton insulated copper wire with leads connected to glass insulated terminals that went through the compressor casing.

A three-point spring suspension was used for the motor-compressor to minimize vibration. The compressor assembly was mounted on a drop-forged base. A drawn steel shell fit into a lead gasketed groove in the base and was secured to the base with bolts. The shell measured approximately 12 in. (30 cm.) tall by 10 in. (25 cm.) wide (Figure 3).

Steenstrup's system design was designated DR, an acronym for *Domestic Refrigerator*. Fifty refrigerators were built in late 1926 and placed in employee's homes so they could be carefully monitored.

In January, 1927, General Electric established the Electric Refrigeration Department. \$18 million (\$158 million in 1996 dollars) was allocated for manufacturing

plant and equipment. Eight million of today's dollar equivalent was spent for national advertising in June, 1927.⁵

The advertising boasted: "Now Comes - Simplified Electric Refrigeration". The ad text noted: "...its operation is practically noiseless three feet from the refrigerator. It uses very little current and no special wiring is needed..."⁶ In fact, the new General Electric refrigerator was very energy efficient compared to its competition, consuming about one-half the energy that most others used.

After 1927, innovative advertising continued, much of it centered on the indestructibility of the sealed refrigeration unit. Ads (Figure 4) showed GE Refrigerators being drowned in water, or burned in fires. The refrigerators still worked!

Advertisement in the print edition formerly in this space.

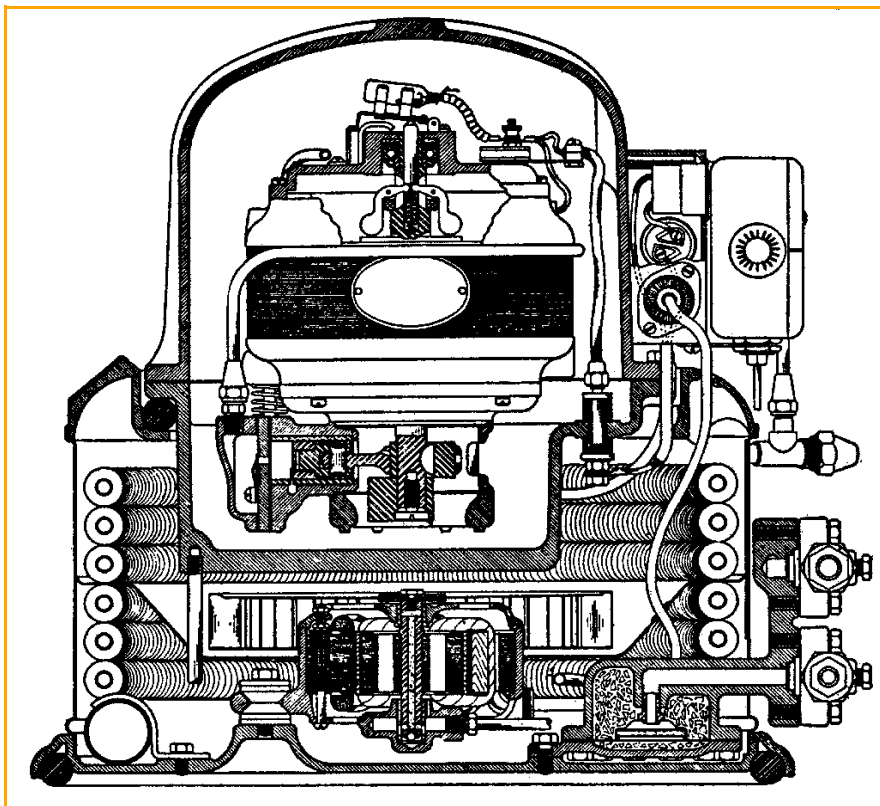

Figure 5 Williams Ice-O-Matic refrigerating unit (From: Hull, H. 1933. *Household Electric Refrigeration*)

There was an attempt to apply the larger DR compressors to air conditioning. Although there were few applications of small size air cooling systems in the late 1920s, the possibilities were envisioned. Alexander Stevenson Jr., Christian Steenstrup's boss, assigned another engineer, Frank Faust, to investigate the feasibility of applying the DR refrigerating system to air cooling in 1928. After a demonstration project confirmed the possibility, Faust was charged with development of a GE room cooler. Faust built two development units in 1930, using the larger DR compressors. Thirty room coolers were manufactured and sold in 1931.¹¹

Unfortunately, extending Steenstrup's compressor design to larger sizes did not prove successful. Durability and cost considerations resulted in discontinuance of the larger DR units in 1931. Belt driven refrigeration units in a range of sizes were developed to fulfill the need for larger units, while engineering work continued on larger hermetic units.¹²

The 1/8 HP compressor in the General Electric DR refrigeration system proved

to be very durable. A large number of them operated 30 to 40 years. Some are still being used, although none of these, to the author's knowledge, date to the first versions made in 1927 or 1928.

(7) **Westinghouse SD:** The Westinghouse Electric and Manufacturing Co. was a relative late comer to the household refrigerator industry. Although the company had been experimenting since 1913, their refrigerator did not debut until 1930.

Refrigeration system development engineering took place under the guidance of Matson Terry. The work focused on sealed systems after 1921.¹³ There were a large number of U.S. patents issued in the 1920s, some to Terry, but most to Terry's staff engineer Andrew Kutcher. These patents detail various types of rotary vane compressors using ethyl chloride refrigerant.¹⁴

The final version placed in production abandoned the previous concepts, and used a bolted iron compressor using a reciprocating compressor with sulfur dioxide refrigerant.

One curious feature of the Westinghouse compressor was the use of a roller bearing for the connecting rod. A split-

phase induction motor was used, necessitating an unloaded start.

This was accomplished with a magnetic unloader assembly which was activated by the starting current inrush. The unloader bypassed the cylinder discharge to the low side, and was deactivated as the starting current decreased when the motor came up to full operating speed.

The compressor was produced in two sizes, with 1/8 and 1/6 HP motors, designated as SD and ASD respectively. The motor featured thermostatic overload protection using the "Spencer Disk." This was a bimetallic, concave disk, attached to the outside of the motor housing. Electrical contacts, in series with the compressor motor, were mounted on the rim of the disk.

If the motor housing became hot from overload, the bimetal construction would force the disk into a concave shape, opening the contacts. As the motor cooled, the disk would pop back into its original convex shape, closing the electrical contacts.¹⁵

This ingenious device was manufactured by the Spencer Thermostat Co. and was soon tradenamed *KLIXON*. It was widely adopted for motor protection. The bolted compressor was produced for two years, 1930 and 1931. In 1932, a fully hermetic compressor replaced the bolted design. The hermetic version will be discussed in the next part of this series.

(8) **Williams Ice-O-Matic:** The Williams Oil-O-Matic Heating Corporation, known for its line of oil burners, entered the electric refrigeration field in 1932. One of their refrigerators featured a bolted shell hermetic compressor. The external appearance of this refrigeration unit was similar to the General Electric Monitor Top, but the Williams unit was designated the "Capitol" Ice-O-Matic because its shape resembled the U.S. Capitol building dome in Washington. The Capitol unit housed a finned air-cooled condenser cooled by a squirrel cage fan. The compressor was a 1/6 HP single cylinder reciprocating type using Methyl Chloride refrigerant. The starting winding of the split-phase induction motor was disconnected by a speed governor which tripped a bulb containing electrical contacts and mercury (Figure 5).

There is no mention of any means of reducing starting torque in any of the literature the author checked. The Capitol unit was made for only one year: 1932.

